

The S-805 Series is a non-adjusting voltage detector made using a CMOS process. The detection voltage is fixed internally. The voltage detectors are composed of a high-precision and low power consumption standard voltage source, a comparator, a hysteresis circuit, and an output driver. Output forms are Nch opendrain and CMOS output, both of which have various product line ups. Since the S-805 Series needs a typical power consumption of 1.4  $\mu\text{A}$ , much lower than other voltage monitoring ICs, battery-powered portable equipment can have a higher capacity and a longer service life.

### ■ Features

- Low power consumption  
( $V_{DD} = 1.5\text{ V}$ : 1.4  $\mu\text{A}$  typ.)
- Low resetting output minimum guarantee voltage  
(S-8051ANB, S-8051ANB-NA-X : 0.9 V typ.)
- High-stable standard voltage source built-in  
(0.8 V typ.)
- Hysteresis characteristic  
(S-8054HN, S-8054HN-CB-X: 200 mV typ.)
- Good temperature characteristic of detection voltage  
(S-8051ANB, S-8051ANB-NA-X:  $\pm 0.13\text{ mV}/^\circ\text{C}$  typ.)
- TO-92 or mini-power mold packages are available

### ■ Applications

- Battery checker
- Level selector
- Battery backup of memories
- Power failure detector
- Reset for microcomputer etc.
- Store signal detector for non-volatile RAM

### ■ Pin Arrangement

(1) TO-92

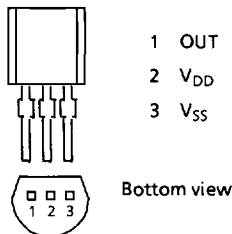

Figure 1

(2) SOT-89-3 mini-power mold

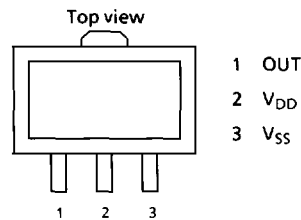

Figure 2

# VOLTAGE DETECTOR S-805 Series

## Block Diagram

(1) Nch opendrain output

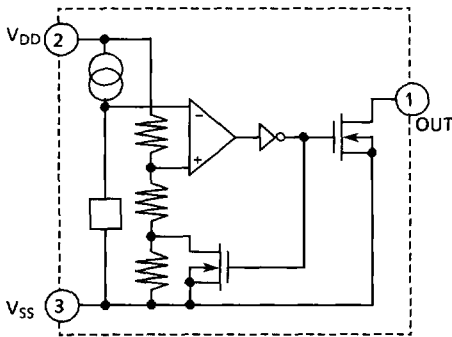
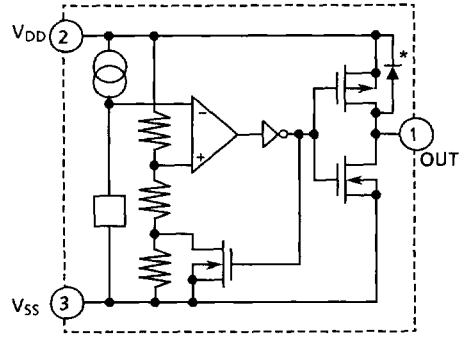

Figure 3

(2) CMOS output



\* Parasitic diode

Figure 4

## Absolute Maximum Ratings

Table 1

(Unless otherwise specified :  $T_a = 25^\circ\text{C}$ )

Parameter	Symbol	Ratings	Unit
Power supply voltage	$V_{DD} - V_{SS}$	12.0	V
Input voltage	$V_{IN}$	$V_{SS} - 0.3$ to $V_{DD} + 0.3$	
Output voltage	$V_{OUT}$	$V_{SS} - 0.3$ to 12	
		$V_{SS} - 0.3$ to $V_{IN} + 0.3$	
Output current	$I_{OUT}$	50	mA
Power dissipation	$P_D$	200	mW
Operating temperature	$T_{opr}$	- 20 to + 70	°C
Storage temperature	$T_{stg}$	- 40 to + 125	

**Caution** : Keep static electricity to a minimum.

■ **Selection Guide**

The S-805 Series has 21 products with a detection voltage range of 1.0 V to 5.2 V.

A selection can be made according to detection voltage range, output form and package.

**Table 2**

Detection voltage range (V)	Hysteresis width (V, typ.)	Output form	Product name	
			TO-92	SOT-89-3 (Mini-power mold)*
0.995 to 1.105	0.053	Nch opendrain	S-8051ANB	S-8051ANB-NA-X
1.095 to 1.205	0.058	Nch opendrain	S-8051ANR	S-8051ANR-NB-X
1.795 to 2.005	0.095	Nch opendrain	—	S-8051HN-CD-X
1.995 to 2.205	0.105	Nch opendrain	—	S-8052ANB-NE-X
1.995 to 2.205	0.105	CMOS	S-8052ALB	S-8052ALB-LE-X
2.195 to 2.405	0.115	CMOS	S-8052ALR	S-8052ALR-LF-X
2.295 to 2.505	2.000	Nch opendrain	S-8052HNM	S-8052HNM-CR-X
2.395 to 2.605	0.125	CMOS	S-8052ALO	S-8052ALO-LG-X
2.595 to 2.805	0.135	CMOS	S-8052ALY	S-8052ALY-LH-X
2.595 to 2.805	0.135	Nch opendrain	—	S-8052ANY-NH-X
2.795 to 3.105	0.148	CMOS	S-8053ALB	S-8053ALB-LI-X
2.895 to 3.105	0.150	CMOS	S-8053HLB	—
2.895 to 3.105	0.150	Nch opendrain	S-8053HNB	—
3.095 to 3.405	0.163	CMOS	S-8053ALR	S-8053ALR-LJ-X
3.395 to 3.705	0.178	Nch opendrain	S-8053ANO	—
3.995 to 4.305	0.208	CMOS	S-8054ALB	S-8054ALB-LM-X
4.295 to 4.605	0.223	CMOS	S-8054ALR	S-8054ALR-LN-X
4.595 to 4.905	0.238	CMOS	S-8054ALO	S-8054ALO-LO-X
4.895 to 5.205	0.253	CMOS	S-8054ALY	S-8054ALY-LP-X
3.80 to 4.20	0.200	Nch opendrain	S-8054HNB	S-8054HNB-CB-X
4.50 to 4.70	0.050	Nch opendrain	S-8054HNM	S-8054HNM-CQ-X

\* The last digit of the model name changes depending upon the packing form when it is an SOT-89-3 package product.

S : Stick

T : Tape (T1 and T2 types are available depending on the direction of detectors on the tape.)

# VOLTAGE DETECTOR

## S-805 Series

### Output Configurations

#### 1. S-805 Series model numbering conventions

	Nch open-drain ("L" reset type)	CMOS output ("L" reset type)
S-805 Series	"N" is the second to the last letter of the model number. Ex. S-8052ANY	"L" is the second to the last letter of the model number. Ex. S-8054ALB

#### 2. Output configurations and their implementations

Implementation	Nch	CMOS ("L")
With different power supplies	○	×
With active low reset CPUs	○	○
With active high reset CPUs	×	×
As power resets employing CR circuits	○	×
With voltage divider resistors to vary ( $-V_{DET}$ )	○	×

· Example with two power supplies

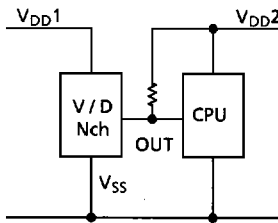

· Examples with one power supply

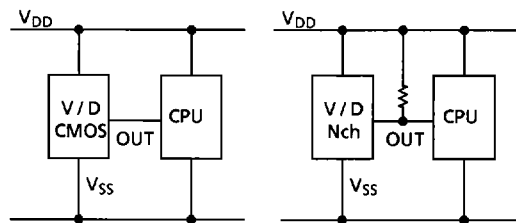

or

Figure 5

■ **Electrical Characteristics**

1. S-8051 Series

The S-8051 Series (except the S-8051HN-CD) is suitable for detecting voltage when using only a battery.

1.1 S-8051ANB, S-8051ANB-NA-X (Detection voltage: 0.995 V to 1.105 V)

**Table 3**

(Unless otherwise specified : Ta = 25°C)

Parameter	Symbol	Conditions	Min.	Typ.	Max.	Unit	Test circuit
Detection voltage	$-V_{DET}$		0.995	1.05	1.105	V	1
Hysteresis width	$V_{HYS}$		—	$-V_{DET} \times 0.05$	—	V	1
Current consumption	$I_{SS}$	$V_{DD} = 1.5\text{ V}$	—	1.4	3.0	$\mu\text{A}$	2
Operating voltage	$V_{DD}$		0.9	—	5.0	V	1
Output current	$I_{OUT}$	$N_{ch}$ $V_{DS} = 0.5\text{ V}$ $V_{DD} = 0.95\text{ V}$	0.03	0.25	—	mA	3
Temperature characteristic of $-V_{DET}$	$\frac{\Delta -V_{DET}}{\Delta T_a}$	$-20^\circ\text{C} \leq T_a \leq 70^\circ\text{C}$	—	$\pm 0.13$	—	mV/°C	—

1.2 S-8051ANR, S-8051ANR-NB-X (Detection voltage: 1.095 V to 1.205 V)

**Table 4**

(Unless otherwise specified : Ta = 25°C)

Parameter	Symbol	Conditions	Min.	Typ.	Max.	Unit	Test circuit
Detection voltage	$-V_{DET}$		1.095	1.15	1.205	V	1
Hysteresis width	$V_{HYS}$		—	$-V_{DET} \times 0.05$	—	V	1
Current consumption	$I_{SS}$	$V_{DD} = 1.5\text{ V}$	—	1.4	3.0	$\mu\text{A}$	2
Operating voltage	$V_{DD}$		1.0	—	5.0	V	1
Output current	$I_{OUT}$	$N_{ch}$ $V_{DS} = 0.5\text{ V}$ $V_{DD} = 1.05\text{ V}$	0.03	0.25	—	mA	3
Temperature characteristic of $-V_{DET}$	$\frac{\Delta -V_{DET}}{\Delta T_a}$	$-20^\circ\text{C} \leq T_a \leq 70^\circ\text{C}$	—	$\pm 0.14$	—	mV/°C	—

1.3 S-8051HN-CD-X (Detection voltage: 1.795 V to 2.005 V)

**Table 5**

(Unless otherwise specified : Ta = 25°C)

Parameter	Symbol	Conditions	Min.	Typ.	Max.	Unit	Test circuit
Detection voltage	$-V_{DET}$		1.795	1.90	2.005	V	1
Hysteresis width	$V_{HYS}$		—	$-V_{DET} \times 0.05$	—	V	1
Current consumption	$I_{SS}$	$V_{DD} = 3.0\text{ V}$	—	1.8	4.0	$\mu\text{A}$	2
Operating voltage	$V_{DD}$		1.5	—	10.0	V	1
Output current	$I_{OUT}$	$N_{ch}$ $V_{DS} = 0.5\text{ V}$ $V_{DD} = 0.95\text{ V}$ $V_{DD} = 1.20\text{ V}$	0.03 0.23	0.25 0.50	— —	mA	3
Temperature characteristic of $-V_{DET}$	$\frac{\Delta -V_{DET}}{\Delta T_a}$	$-20^\circ\text{C} \leq T_a \leq 70^\circ\text{C}$	—	$\pm 0.23$	—	mV/°C	—

# VOLTAGE DETECTOR

## S-805 Series

### 2. S-8052 Series

The S-8052 Series is used for resetting CMOS CPUs. Especially, the S-8052HNM and S-8052HNM-CR are ideal for detection of backup power supply.

#### 2.1 S-8052ANB-NE-X (Detection voltage: 1.995 V to 2.205 V)

**Table 6**

(Unless otherwise specified : Ta = 25°C)

Parameter	Symbol	Conditions	Min.	Typ.	Max.	Unit	Test circuit	
Detection voltage	$-V_{DET}$		1.995	2.10	2.205	V	1	
Hysteresis width	$V_{HYS}$		—	$-V_{DET} \times 0.05$	—	V	1	
Current consumption	$I_{SS}$	$V_{DD} = 3.0\text{ V}$	—	1.8	4.0	$\mu\text{A}$	2	
Operating voltage	$V_{DD}$		1.5	—	10.0	V	1	
Output current	$I_{OUT}$	Nch $V_{DS} = 0.5\text{ V}$	$V_{DD} = 0.95\text{ V}$	0.03	0.25	—	mA	3
			$V_{DD} = 1.20\text{ V}$	0.23	0.50	—		
Temperature characteristic of $-V_{DET}$	$\frac{\Delta(-V_{DET})}{\Delta T_a}$	$-20^\circ\text{C} \leq T_a \leq 70^\circ\text{C}$	—	$\pm 0.26$	—	mV/°C	—	

#### 2.2 S-8052ALB, S-8052ALB-LE-X (Detection voltage: 1.995 V to 2.205 V)

**Table 7**

(Unless otherwise specified : Ta = 25°C)

Parameter	Symbol	Conditions	Min.	Typ.	Max.	Unit	Test circuit	
Detection voltage	$-V_{DET}$		1.995	2.10	2.205	V	1	
Hysteresis width	$V_{HYS}$		—	$-V_{DET} \times 0.05$	—	V	1	
Current consumption	$I_{SS}$	$V_{DD} = 3.0\text{ V}$	—	1.8	4.0	$\mu\text{A}$	2	
Operating voltage	$V_{DD}$		1.5	—	10.0	V	1	
Output current	$I_{OUT}$	Nch $V_{DS} = 0.5\text{ V}$	$V_{DD} = 0.95\text{ V}$	0.03	0.25	—	mA	3
			$V_{DD} = 1.2\text{ V}$	0.23	0.50	—		
		Pch $V_{DS} = 2.1\text{ V}$	$V_{DD} = 4.5\text{ V}$	0.04	—	—		4
Temperature characteristic of $-V_{DET}$	$\frac{\Delta(-V_{DET})}{\Delta T_a}$	$-20^\circ\text{C} \leq T_a \leq 70^\circ\text{C}$	—	$\pm 0.26$	—	mV/°C	—	

#### 2.3 S-8052ALR, S-8052ALR-LF-X (Detection voltage: 2.195 V to 2.405 V)

**Table 8**

(Unless otherwise specified : Ta = 25°C)

Parameter	Symbol	Conditions	Min.	Typ.	Max.	Unit	Test circuit	
Detection voltage	$-V_{DET}$		2.195	2.30	2.405	V	1	
Hysteresis width	$V_{HYS}$		—	$-V_{DET} \times 0.05$	—	V	1	
Current consumption	$I_{SS}$	$V_{DD} = 3.0\text{ V}$	—	1.8	4.0	$\mu\text{A}$	2	
Operating voltage	$V_{DD}$		1.5	—	10.0	V	1	
Output current	$I_{OUT}$	Nch $V_{DS} = 0.5\text{ V}$	$V_{DD} = 0.95\text{ V}$	0.03	0.25	—	mA	3
			$V_{DD} = 1.2\text{ V}$	0.23	0.50	—		
		Pch $V_{DS} = 2.1\text{ V}$	$V_{DD} = 4.5\text{ V}$	0.04	—	—		4
Temperature characteristic of $-V_{DET}$	$\frac{\Delta(-V_{DET})}{\Delta T_a}$	$-20^\circ\text{C} \leq T_a \leq 70^\circ\text{C}$	—	$\pm 0.28$	—	mV/°C	—	

2.4 S-8052ALO, S-8052ALO-LG-X (Detection voltage: 2.395 V to 2.605 V)

**Table 9**

(Unless otherwise specified : Ta = 25°C)

Parameter	Symbol	Conditions	Min.	Typ.	Max.	Unit	Test circuit	
Detection voltage	$-V_{DET}$		2.395	2.50	2.605	V	1	
Hysteresis width	$V_{HYS}$		—	$-V_{DET} \times 0.05$	—	V	1	
Current consumption	$I_{SS}$	$V_{DD} = 3.0\text{ V}$	—	1.8	4.0	$\mu\text{A}$	2	
Operating voltage	$V_{DD}$		1.5	—	10.0	V	1	
Output current	$I_{OUT}$	Nch $V_{DS} = 0.5\text{ V}$	$V_{DD} = 0.95\text{ V}$	0.03	0.25	—	mA	3
			$V_{DD} = 1.2\text{ V}$	0.23	0.50	—		
		Pch $V_{DS} = 2.1\text{ V}$	$V_{DD} = 4.5\text{ V}$	0.04	—	—	4	
Temperature characteristic of $-V_{DET}$	$\frac{\Delta -V_{DET}}{\Delta T_a}$	$-20^\circ\text{C} \leq T_a \leq 70^\circ\text{C}$	—	$\pm 0.31$	—	mV/°C	—	

2.5 S-8052ALY, S-8052ALY-LH-X (Detection voltage: 2.595 V to 2.805 V)

**Table 10**

(Unless otherwise specified : Ta = 25°C)

Parameter	Symbol	Conditions	Min.	Typ.	Max.	Unit	Test circuit	
Detection voltage	$-V_{DET}$		2.595	2.70	2.805	V	1	
Hysteresis width	$V_{HYS}$		—	$-V_{DET} \times 0.05$	—	V	1	
Current consumption	$I_{SS}$	$V_{DD} = 3.0\text{ V}$	—	1.8	4.0	$\mu\text{A}$	2	
Operating voltage	$V_{DD}$		1.5	—	10.0	V	1	
Output current	$I_{OUT}$	Nch $V_{DS} = 0.5\text{ V}$	$V_{DD} = 0.95\text{ V}$	0.03	0.25	—	mA	3
			$V_{DD} = 1.2\text{ V}$	0.23	0.50	—		
		Pch $V_{DS} = 2.1\text{ V}$	$V_{DD} = 4.5\text{ V}$	0.04	—	—	4	
Temperature characteristic of $-V_{DET}$	$\frac{\Delta -V_{DET}}{\Delta T_a}$	$-20^\circ\text{C} \leq T_a \leq 70^\circ\text{C}$	—	$\pm 0.34$	—	mV/°C	—	

2.6 S-8052ANY-NH-X (Detection voltage : 2.595 V to 2.805 V)

**Table 11**

(Unless otherwise specified : Ta = 25°C)

Parameter	Symbol	Conditions	Min.	Typ.	Max.	Unit	Test circuit	
Detection voltage	$-V_{DET}$		2.595	2.70	2.805	V	1	
Hysteresis width	$V_{HYS}$		—	$-V_{DET} \times 0.05$	—	V	1	
Current consumption	$I_{SS}$	$V_{DD} = 3.0\text{ V}$	—	1.8	4.0	$\mu\text{A}$	2	
Operating voltage	$V_{DD}$		1.5	—	10.0	V	1	
Output current	$I_{OUT}$	Nch $V_{DS} = 0.5\text{ V}$	$V_{DD} = 0.95\text{ V}$	0.03	0.25	—	mA	3
			$V_{DD} = 1.20\text{ V}$	0.23	0.50	—		
Temperature characteristic of $-V_{DET}$	$\frac{\Delta -V_{DET}}{\Delta T_a}$	$-20^\circ\text{C} \leq T_a \leq 70^\circ\text{C}$	—	$\pm 0.34$	—	mV/°C	—	

## VOLTAGE DETECTOR S-805 Series

### 2.7 S-8052HNM, S-8052HNM-CR-X (Detection voltage: 2.295 V to 2.505 V)

**Table 12**

(Unless otherwise specified : Ta = 25°C)

Parameter	Symbol	Conditions	Min.	Typ.	Max.	Unit	Test circuit	
Detection voltage	$-V_{DET}$		2.295	2.40	2.505	V	1	
Release voltage	$+V_{DET}$		4.300	4.400	4.500	V	1	
Current consumption	$I_{SS}$	$V_{DD} = 6.0\text{ V}$	—	2.6	6.0	$\mu\text{A}$	2	
Operating voltage	$V_{DD}$		1.5	—	10.0	V	1	
Output current	$I_{OUT}$	Nch $V_{DS} = 0.5\text{ V}$	$V_{DD} = 0.95\text{ V}$	0.03	0.25	—	mA	3
			$V_{DD} = 1.20\text{ V}$	0.23	0.50	—		
Temperature characteristic of $-V_{DET}$	$\frac{\Delta -V_{DET}}{\Delta T_a}$	$-20^\circ\text{C} \leq T_a \leq 70^\circ\text{C}$	—	$\pm 0.33$	—	mV/°C	—	

### 3. S-8053 Series

The S-8053 Series is suitable for detecting voltage when using three batteries or for resetting CMOS CPUs.

#### 3.1 S-8053ALB, S-8053ALB-LI-X (Detection voltage: 2.795 V to 3.105 V)

**Table 13**

(Unless otherwise specified : Ta = 25°C)

Parameter	Symbol	Conditions	Min.	Typ.	Max.	Unit	Test circuit	
Detection voltage	$-V_{DET}$		2.795	2.95	3.105	V	1	
Hysteresis width	$V_{HYS}$		—	$-V_{DET} \times 0.05$	—	V	1	
Current consumption	$I_{SS}$	$V_{DD} = 4.5\text{ V}$	—	2.2	5.0	$\mu\text{A}$	2	
Operating voltage	$V_{DD}$		1.6	—	10.0	V	1	
Output current	$I_{OUT}$	Nch $V_{DS} = 0.5\text{ V}$	$V_{DD} = 1.2\text{ V}$	0.23	0.50	—	mA	3
			$V_{DD} = 2.4\text{ V}$	1.60	3.70	—		
		Pch $V_{DS} = 2.1\text{ V}$	$V_{DD} = 4.5\text{ V}$	0.04	—	—	4	
Temperature characteristic of $-V_{DET}$	$\frac{\Delta -V_{DET}}{\Delta T_a}$	$-20^\circ\text{C} \leq T_a \leq 70^\circ\text{C}$	—	$\pm 0.37$	—	mV/°C	—	

#### 3.2 S-8053HLB (Detection voltage: 2.895 V to 3.105 V)

**Table 14**

(Unless otherwise specified : Ta = 25°C)

Parameter	Symbol	Conditions	Min.	Typ.	Max.	Unit	Test circuit	
Detection voltage	$-V_{DET}$		2.895	3.00	3.105	V	1	
Hysteresis width	$V_{HYS}$		—	$-V_{DET} \times 0.05$	—	V	1	
Current consumption	$I_{SS}$	$V_{DD} = 4.5\text{ V}$	—	2.2	5.0	$\mu\text{A}$	2	
Operating voltage	$V_{DD}$		1.6	—	10.0	V	1	
Output current	$I_{OUT}$	Nch $V_{DS} = 0.5\text{ V}$	$V_{DD} = 1.2\text{ V}$	0.23	0.50	—	mA	3
			$V_{DD} = 2.4\text{ V}$	1.60	3.70	—		
		Pch $V_{DS} = 2.1\text{ V}$	$V_{DD} = 4.5\text{ V}$	0.04	—	—	4	
Temperature characteristic of $-V_{DET}$	$\frac{\Delta -V_{DET}}{\Delta T_a}$	$-20^\circ\text{C} \leq T_a \leq 70^\circ\text{C}$	—	$\pm 0.38$	—	mV/°C	—	



3.3 S-8053HNB (Detection voltage: 2.895 V to 3.105 V)

**Table 15**

(Unless otherwise specified : Ta = 25°C)

Parameter	Symbol	Conditions	Min.	Typ.	Max.	Unit	Test circuit	
Detection voltage	$-V_{DET}$		2.895	3.00	3.105	V	1	
Hysteresis width	$V_{HYS}$		—	$-V_{DET} \times 0.05$	—	V	1	
Current consumption	$I_{SS}$	$V_{DD} = 4.5\text{ V}$	—	2.2	5.0	$\mu\text{A}$	2	
Operating voltage	$V_{DD}$		1.6	—	10.0	V	1	
Output current	$I_{OUT}$	Nch $V_{DS} = 0.5\text{ V}$	$V_{DD} = 1.2\text{ V}$	0.23	0.50	—	mA	3
			$V_{DD} = 2.4\text{ V}$	1.60	3.70	—		
Temperature characteristic of $-V_{DET}$	$\frac{\Delta -V_{DET}}{\Delta Ta}$	$-20^\circ\text{C} \leq Ta \leq 70^\circ\text{C}$	—	$\pm 0.37$	—	mV/°C	—	

3.4 S-8053ALR, S-8053ALR-LJ-X (Detection voltage: 3.095 V to 3.405 V)

**Table 16**

(Unless otherwise specified : Ta = 25°C)

Parameter	Symbol	Conditions	Min.	Typ.	Max.	Unit	Test circuit	
Detection voltage	$-V_{DET}$		3.095	3.25	3.405	V	1	
Hysteresis width	$V_{HYS}$		—	$-V_{DET} \times 0.05$	—	V	1	
Current consumption	$I_{SS}$	$V_{DD} = 4.5\text{ V}$	—	2.2	5.0	$\mu\text{A}$	2	
Operating voltage	$V_{DD}$		1.6	—	10.0	V	1	
Output current	$I_{OUT}$	Nch $V_{DS} = 0.5\text{ V}$	$V_{DD} = 1.2\text{ V}$	0.23	0.50	—	mA	3
			$V_{DD} = 2.4\text{ V}$	1.60	3.70	—		
		Pch $V_{DS} = 2.1\text{ V}$	$V_{DD} = 4.5\text{ V}$	0.04	—	—		4
Temperature characteristic of $-V_{DET}$	$\frac{\Delta -V_{DET}}{\Delta Ta}$	$-20^\circ\text{C} \leq Ta \leq 70^\circ\text{C}$	—	$\pm 0.41$	—	mV/°C	—	

3.5 S-8053ANO (Detection voltage: 3.395 V to 3.705 V)

**Table 17**

(Unless otherwise specified : Ta = 25°C)

Parameter	Symbol	Conditions	Min.	Typ.	Max.	Unit	Test circuit	
Detection voltage	$-V_{DET}$		3.395	3.55	3.705	V	1	
Hysteresis width	$V_{HYS}$		—	$-V_{DET} \times 0.05$	—	V	1	
Current consumption	$I_{SS}$	$V_{DD} = 4.5\text{ V}$	—	2.2	5.0	$\mu\text{A}$	2	
Operating voltage	$V_{DD}$		1.6	—	10.0	V	1	
Output current	$I_{OUT}$	Nch $V_{DS} = 0.5\text{ V}$	$V_{DD} = 1.2\text{ V}$	0.23	0.50	—	mA	3
			$V_{DD} = 2.4\text{ V}$	1.60	3.70	—		
Temperature characteristic of $-V_{DET}$	$\frac{\Delta -V_{DET}}{\Delta Ta}$	$-20^\circ\text{C} \leq Ta \leq 70^\circ\text{C}$	—	$\pm 0.44$	—	mV/°C	—	

## VOLTAGE DETECTOR

### S-805 Series

#### 4. S-8054 Series

The S-8054 Series is suitable for 5-V power monitor or resetting CPUs.

##### 4.1 S-8054ALB, S-8054ALB-LM-X (Detection voltage: 3.995 V to 4.305 V)

**Table 18**

(Unless otherwise specified : Ta = 25°C)

Parameter	Symbol	Conditions	Min.	Typ.	Max.	Unit	Test circuit	
Detection voltage	$-V_{DET}$		3.995	4.15	4.305	V	1	
Hysteresis width	$V_{HYS}$		—	$-V_{DET} \times 0.05$	—	V	1	
Current consumption	$I_{SS}$	$V_{DD} = 6.0\text{ V}$	—	2.6	6.0	$\mu\text{A}$	2	
Operating voltage	$V_{DD}$		1.6	—	10.0	V	1	
Output current	$I_{OUT}$	Nch $V_{DS} = 0.5\text{ V}$	$V_{DD} = 1.2\text{ V}$	0.23	0.50	—	mA	3
			$V_{DD} = 2.4\text{ V}$	1.60	3.70	—		
			$V_{DD} = 3.6\text{ V}$	3.18	7.00	—		
		Pch $V_{DS} = 2.1\text{ V}$	$V_{DD} = 8.0\text{ V}$	1.00	—	—	4	
Temperature characteristic of $-V_{DET}$	$\frac{\Delta -V_{DET}}{\Delta T_a}$	$-20^\circ\text{C} \leq T_a \leq 70^\circ\text{C}$	—	$\pm 0.52$	—	mV/°C	—	

##### 4.2 S-8054ALR, S-8054ALR-LN-X (Detection voltage: 4.295 V to 4.605 V)

**Table 19**

(Unless otherwise specified : Ta = 25°C)

Parameter	Symbol	Conditions	Min.	Typ.	Max.	Unit	Test circuit	
Detection voltage	$-V_{DET}$		4.295	4.45	4.605	V	1	
Hysteresis width	$V_{HYS}$		—	$-V_{DET} \times 0.05$	—	V	1	
Current consumption	$I_{SS}$	$V_{DD} = 6.0\text{ V}$	—	2.6	6.0	$\mu\text{A}$	2	
Operating voltage	$V_{DD}$		1.6	—	10.0	V	1	
Output current	$I_{OUT}$	Nch $V_{DS} = 0.5\text{ V}$	$V_{DD} = 1.2\text{ V}$	0.23	0.50	—	mA	3
			$V_{DD} = 2.4\text{ V}$	1.60	3.70	—		
			$V_{DD} = 3.6\text{ V}$	3.18	7.00	—		
		Pch $V_{DS} = 2.1\text{ V}$	$V_{DD} = 8.0\text{ V}$	1.00	—	—	4	
Temperature characteristic of $-V_{DET}$	$\frac{\Delta -V_{DET}}{\Delta T_a}$	$-20^\circ\text{C} \leq T_a \leq 70^\circ\text{C}$	—	$\pm 0.56$	—	mV/°C	—	

4.3 S-8054ALO, S-8054ALO-LO-X (Detection voltage: 4.595 V to 4.905 V)

**Table 20**

(Unless otherwise specified : Ta = 25°C)

Parameter	Symbol	Conditions	Min.	Typ.	Max.	Unit	Test circuit	
Detection voltage	$-V_{DET}$		4.595	4.75	4.905	V	1	
Hysteresis width	$V_{HYS}$		—	$-V_{DET} \times 0.05$	—	V	1	
Current consumption	$I_{SS}$	$V_{DD} = 6.0\text{ V}$	—	2.6	6.0	$\mu\text{A}$	2	
Operating voltage	$V_{DD}$		1.6	—	10.0	V	1	
Output current	$I_{OUT}$	Nch $V_{DS} = 0.5\text{ V}$	$V_{DD} = 1.2\text{ V}$	0.23	0.50	—	mA	3
			$V_{DD} = 2.4\text{ V}$	1.60	3.70	—		
			$V_{DD} = 3.6\text{ V}$	3.18	7.00	—		
		Pch $V_{DS} = 2.1\text{ V}$	$V_{DD} = 8.0\text{ V}$	1.00	—	—	4	
Temperature characteristic of $-V_{DET}$	$\frac{\Delta -V_{DET}}{\Delta T_a}$	$-20^\circ\text{C} \leq T_a \leq 70^\circ\text{C}$	—	$\pm 0.59$	—	mV/°C	—	

4.4 S-8054ALY, S-8054ALY-LP-X (Detection voltage: 4.895 V to 5.205 V)

**Table 21**

(Unless otherwise specified : Ta = 25°C)

Parameter	Symbol	Conditions	Min.	Typ.	Max.	Unit	Test circuit	
Detection voltage	$-V_{DET}$		4.895	5.05	5.205	V	1	
Hysteresis width	$V_{HYS}$		—	$-V_{DET} \times 0.05$	—	V	1	
Current consumption	$I_{SS}$	$V_{DD} = 6.0\text{ V}$	—	2.6	6.0	$\mu\text{A}$	2	
Operating voltage	$V_{DD}$		1.6	—	10.0	V	1	
Output current	$I_{OUT}$	Nch $V_{DS} = 0.5\text{ V}$	$V_{DD} = 1.2\text{ V}$	0.23	0.50	—	mA	3
			$V_{DD} = 2.4\text{ V}$	1.60	3.70	—		
			$V_{DD} = 3.6\text{ V}$	3.18	7.00	—		
		Pch $V_{DS} = 2.1\text{ V}$	$V_{DD} = 8.0\text{ V}$	1.00	—	—	4	
Temperature characteristic of $-V_{DET}$	$\frac{\Delta -V_{DET}}{\Delta T_a}$	$-20^\circ\text{C} \leq T_a \leq 70^\circ\text{C}$	—	$\pm 0.63$	—	mV/°C	—	

4.5 S-8054HN, S-8054HN-CB-X (Detection voltage: 3.80 V to 4.20 V)

**Table 22**

(Unless otherwise specified : Ta = 25°C)

Parameter	Symbol	Conditions	Min.	Typ.	Max.	Unit	Test circuit	
Detection voltage	$-V_{DET}$		3.80	4.00	4.20	V	1	
Hysteresis width	$V_{HYS}$		—	$-V_{DET} \times 0.05$	—	V	1	
Current consumption	$I_{SS}$	$V_{DD} = 6.0\text{ V}$	—	2.6	6.0	$\mu\text{A}$	2	
Operating voltage	$V_{DD}$		1.6	—	10.0	V	1	
Output current	$I_{OUT}$	Nch $V_{DS} = 0.5\text{ V}$	$V_{DD} = 1.2\text{ V}$	0.23	0.50	—	mA	3
			$V_{DD} = 2.4\text{ V}$	1.60	3.70	—		
			$V_{DD} = 3.6\text{ V}$	3.18	7.00	—		
Temperature characteristic of $-V_{DET}$	$\frac{\Delta -V_{DET}}{\Delta T_a}$	$-20^\circ\text{C} \leq T_a \leq 70^\circ\text{C}$	—	$\pm 0.5$	—	mV/°C	—	

# VOLTAGE DETECTOR

## S-805 Series

4.6 S-8054HNM, S-8054HNM-CQ-X (Detection voltage: 4.50 V to 4.70 V)

**Table 23**

(Unless otherwise specified : Ta = 25°C)

Parameter	Symbol	Conditions	Min.	Typ.	Max.	Unit	Test circuit
Detection voltage	$-V_{DET}$		4.50	4.60	4.70	V	1
Hysteresis width	$V_{HYS}$		—	0.05	0.10	V	1
Current consumption	$I_{SS}$	$V_{DD} = 6.0\text{ V}$		2.6	6.0	$\mu\text{A}$	2
Operating voltage	$V_{DD}$		1.5	—	10.0	V	1
Output current	$I_{OUT}$	Nch	$V_{DD} = 1.2\text{ V}$	0.23	0.50	mA	3
		$V_{DS} = 0.5\text{ V}$	$V_{DD} = 2.4\text{ V}$	1.60	3.70		
Temperature characteristic of $-V_{DET}$	$\frac{\Delta -V_{DET}}{\Delta T_a}$	$-20^\circ\text{C} \leq T_a \leq 70^\circ\text{C}$	—	$\pm 0.57$	—	mV/°C	—

### Test Circuits

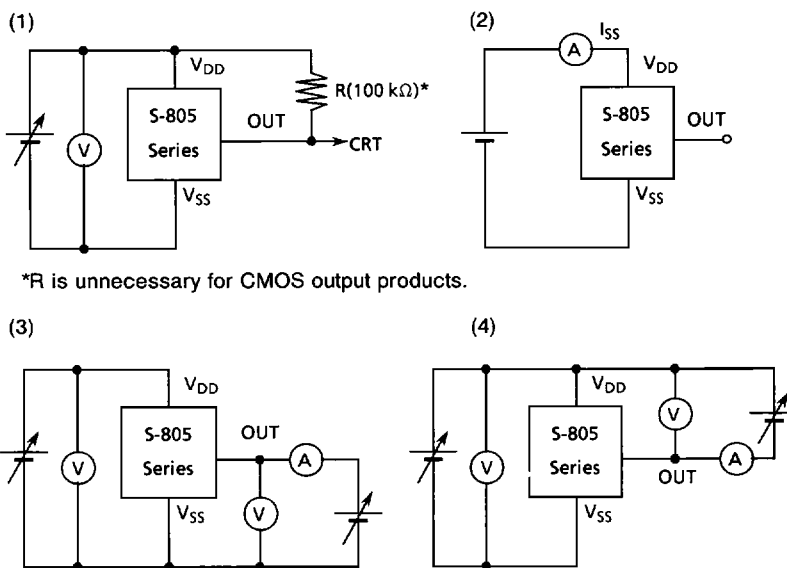

\*R is unnecessary for CMOS output products.

**Figure 6** Test circuit



# VOLTAGE DETECTOR S-805 Series

## ■ Taping

### 1. Tape specifications

T1 and T2 types are available depending upon the direction of ICs on the tape.

(1) White label (without a hole in the center of emboss area)

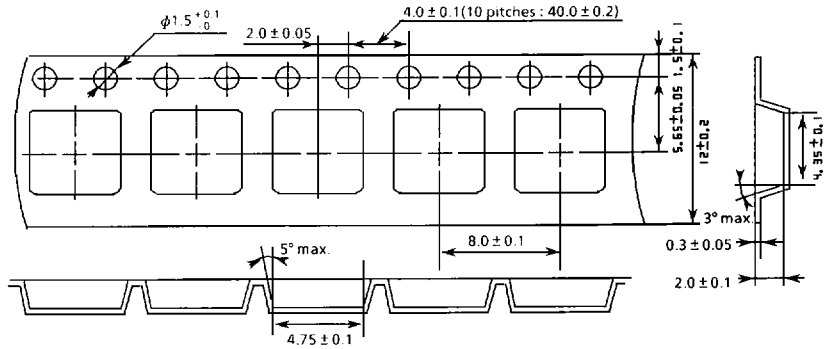

(2) Blue label (with a hole in the center of emboss area)

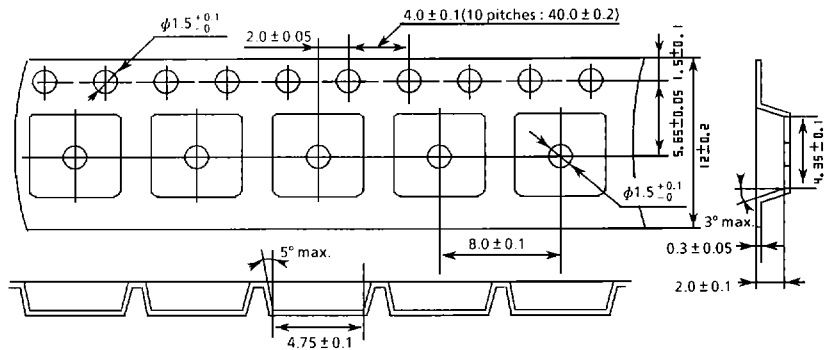

Unit: mm

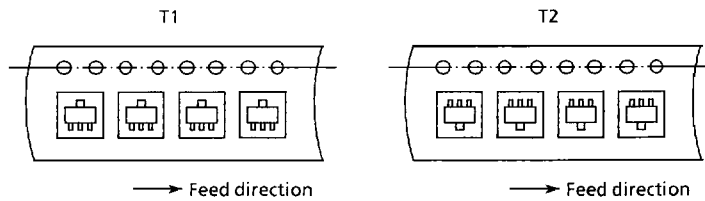

Figure 8

2. Reel specifications

1 reel has 1000 detectors.

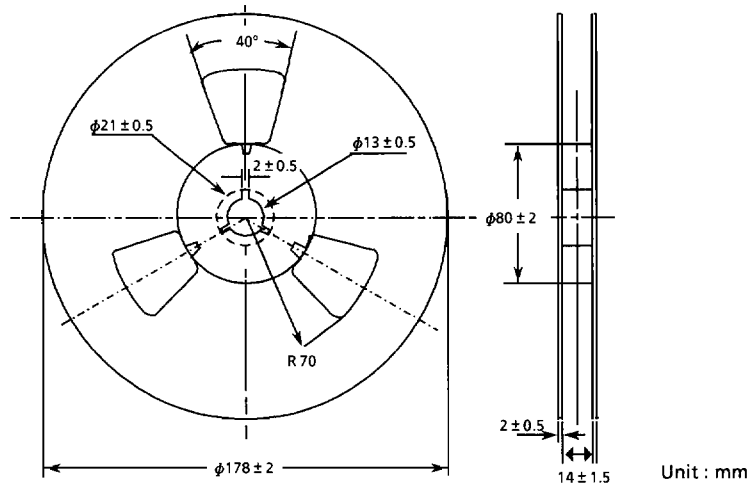

Figure 9

■ Magazine Dimensions

1 stick has 25 detectors.

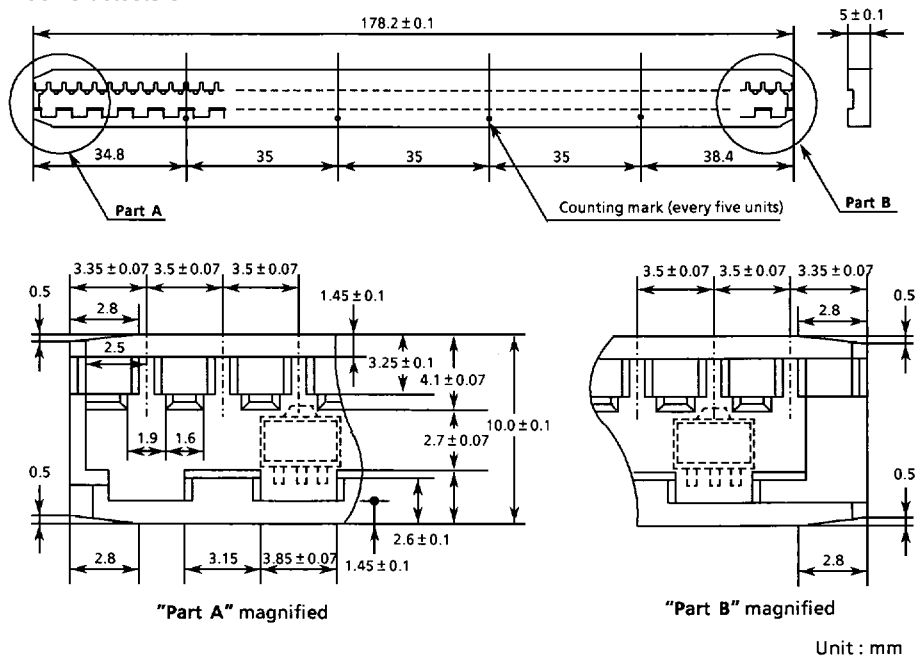

Figure 10

# VOLTAGE DETECTOR

## S-805 Series

### ■ Markings

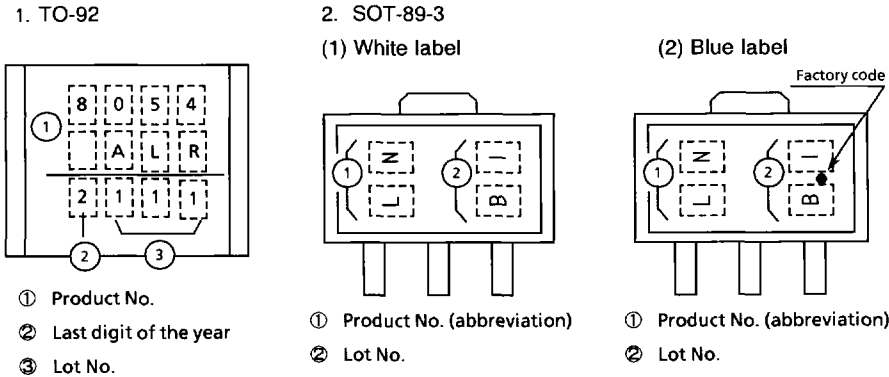

Figure 11 S-8054ALR marking examples

### ■ Technical Terms

#### 1. Detection voltage ( $-V_{DET}$ )

Detection voltage  $-V_{DET}$  is the voltage at which the detector's output goes active. The output goes low on detection. This detection voltage varies slightly among products of the same type. The variation of voltages between the specified minimum [ $(-V_{DET})_{min.}$ ] and maximum [ $(-V_{DET})_{max.}$ ] values is called the detection voltage range. (See Figure 12.)

#### 2. Release voltage ( $+V_{DET}$ )

Release voltage  $+V_{DET}$  is the voltage at which a product's output returns (is "released") to high. The value of this voltage for any single unit lies in a range determined from the value of that product's detection voltage (see Figure 13.):

$$(-V_{DET}) \times 1.02 \leq (+V_{DET}) \leq (-V_{DET}) \times 1.08.$$

When calculating the overall release voltage range for S-805 Series products, care must be taken to consider the variation in the series' detection voltage values. The minimum and maximum values for release voltage [ $(+V_{DET})_{min.}$  and  $(+V_{DET})_{max.}$ ] must be determined using  $(-V_{DET})_{min.}$  and  $(-V_{DET})_{max.}$ :

$$(+V_{DET})_{min.} = [(-V_{DET})_{min.}] \times 1.02;$$

$$(+V_{DET})_{max.} = [(-V_{DET})_{max.}] \times 1.08.$$

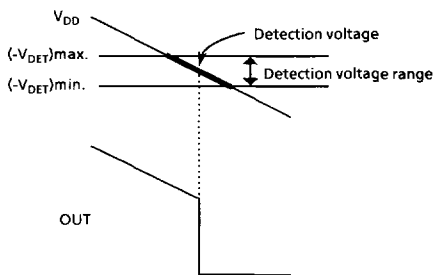

Figure 12

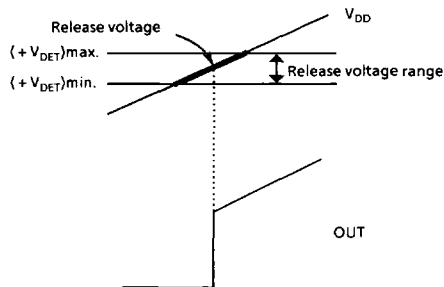

Figure 13



3. Hysteresis width ( $V_{HYS}$ )

Hysteresis width is the voltage difference between a device's detection voltage and its release voltage (see Figure 17.  $V_{HYS} = B - A$ ). By giving a device hysteresis, erroneous toggling of the output due to noise at the input is avoided.

4. Through-type current

Through-type current refers to the instantaneous current flow which occurs at the moment a voltage detector output toggles. This current is quite large in devices with CMOS configured outputs, and also occurs to some extent in Nch open-drain configured devices. (See current consumption characteristics.)

5. Oscillation

In applications where a resistor is connected to the voltage detector input (Figure 14 and 15), the through-type current generated when the output goes from low to high (release) causes a voltage drop equal to [through-type current]  $\times$  [input resistance] across the resistor. When the input voltage resultantly drops below the detection voltage  $-V_{DET}$ , the output voltage returns to its low level. In this state, the through-type current -- and its resultant voltage drop -- have disappeared, and the output goes back from low to high. Again, a through-type current is generated, a voltage drop appears, and the process repeats. Oscillation refers to this unstable condition.

· Power reset mis-implementation

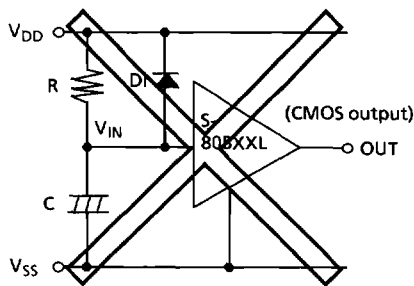

Figure 14

· Mis-implementation with input voltage divider

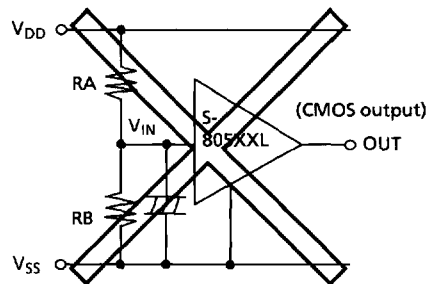

Figure 15

**VOLTAGE DETECTOR**  
**S-805 Series**

■ **Operation**

1. Basic operation

- (1) When power supply voltage  $V_{DD}$  is greater than the release voltage  $+V_{DET}$ , the Nch transistor is OFF and the Pch transistor ON, causing  $V_{DD}$  (high) to appear at the output. With the Nch transistor of Figure 16 (a) off, the comparator input voltage is  $(RB + RC)/(RA + RB + RC) \times V_{DD}$ .
- (2) When power supply voltage  $V_{DD}$  goes below  $+V_{DET}$ , the output continues to maintain the power supply voltage level, as long as  $V_{DD}$  remains above the detection voltage  $-V_{DET}$ . When  $V_{DD}$  does fall below  $-V_{DET}$  (A in Figure 17), the Nch transistor goes ON, the Pch transistor goes OFF, and  $V_{SS}$  appears at the output. With the Nch transistor of Figure 16 (a) ON, the comparator input voltage is  $RB/(RA + RB) \times V_{DD}$ .
- (3) When  $V_{DD}$  falls below the minimum operating voltage, the output becomes undefined. However, output will revert to  $V_{DD}$  if a pull-up has been employed.
- (4)  $V_{SS}$  will again be output when  $V_{DD}$  rises above the minimum operating voltage.  $V_{SS}$  will continue to be output even when  $V_{DD}$  surpasses  $-V_{DET}$ , as long as it does not exceed the release voltage  $+V_{DET}$ .
- (5) When  $V_{DD}$  rises above  $+V_{DET}$  (B in Figure 17), the Nch transistor goes OFF, the Pch transistor goes ON, and  $V_{DD}$  appears at the output.

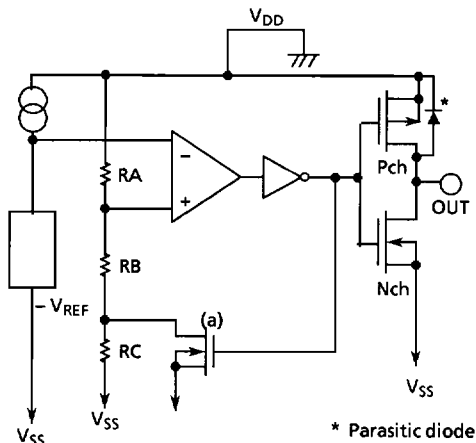

Figure 16

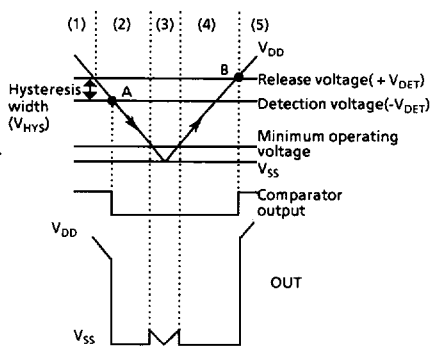

Figure 17

2. Reference voltage circuit

The S-805 Series has 0.8 V typical reference voltage circuit as  $-V_{REF}$  (a high-stable reference voltage source) .

- Features:
- Low power consumption
  - Good temperature characteristic

3. Comparator

The comparator drives a differential amplifier with a current consumption of only  $0.5\mu A$  as shown in Figure 18.

- Features:
- Good relation characteristic
  - Wide operating voltage range
  - Low offset voltage

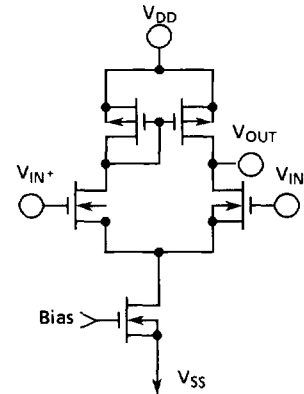

Figure 18 Comparator

4. Other characteristics

(1) Temperature characteristic of detection voltage

Because of the excellent temperature characteristic of the reference voltage circuit, the temperature characteristics of the detection voltage are expressed by the following formula in the range of  $-20^{\circ}C$  to  $70^{\circ}C$ .

$$\frac{-V_{DET}}{-V_{REF}} \times (\pm 0.1) mV/^{\circ}C \text{ typ.}$$

\* $-V_{REF}$  is 0.7 V min., 0.8 V typ., 0.9 V max.

(2) Temperature characteristic of release voltage

$$\frac{-V_{DET} + V_{HYS}}{-V_{REF}} \times (\pm 0.1) mV/^{\circ}C$$

# VOLTAGE DETECTOR

## S-805 Series

### Characteristics

#### 1. Detection voltage ( $V_{DET}$ ) - Temperature ( $T_a$ )

##### 1.1 S-8053ALR, S-8053ALR-LN-X

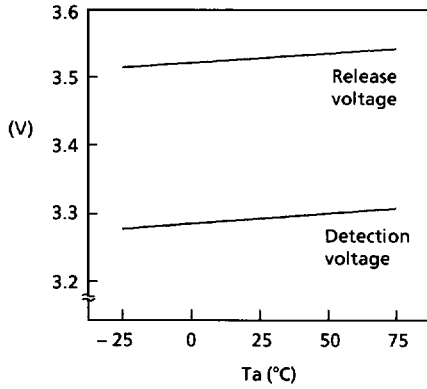

##### 1.2 S-8054HN, S-8054HN-CB-X

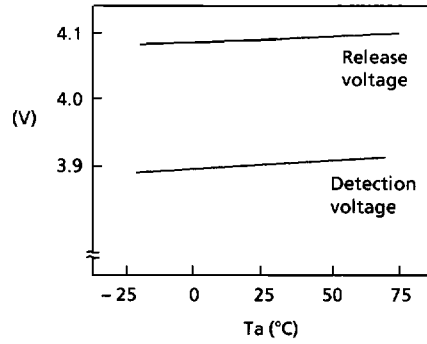

#### 2. Nch transistor current (ex. S-8053ALR, S-8053ALR-LJ-X)

##### 2.1 $V_{DD}$ - $I_{OUT}$

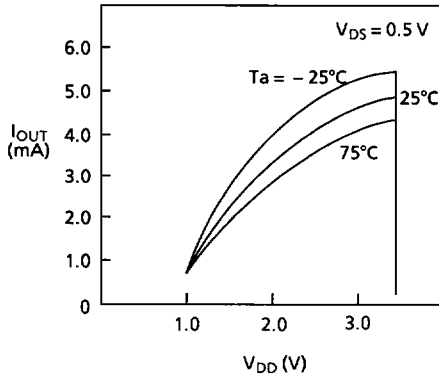

##### 2.2 $V_{DS}$ - $I_{OUT}$ ( $V_{DD}$ parameter)

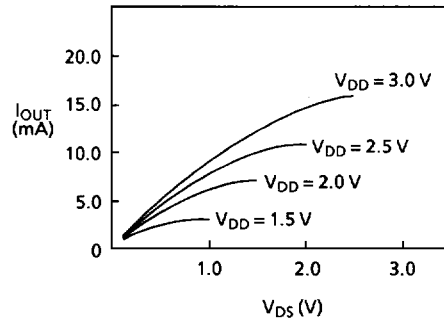

#### 3. Pch transistor current (ex. S-8053ALR, S-8053ALR-LJ-X)

##### 3.1 $V_{DS}$ - $I_{OUT}$

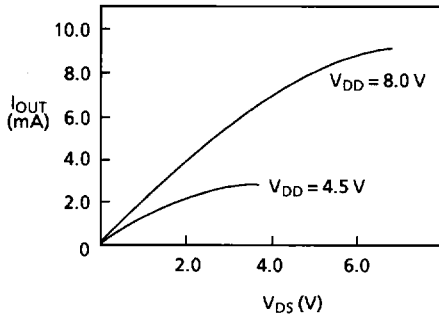

4. Current consumption ( $I_{SS}$ ) - Input voltage ( $V_{IN}$ ) (ex. S-8053ALR, S-8053ALR-LJ-X)

In the detection voltage and the release voltage, a through type current flows for a moment by inverting the level shift internally.

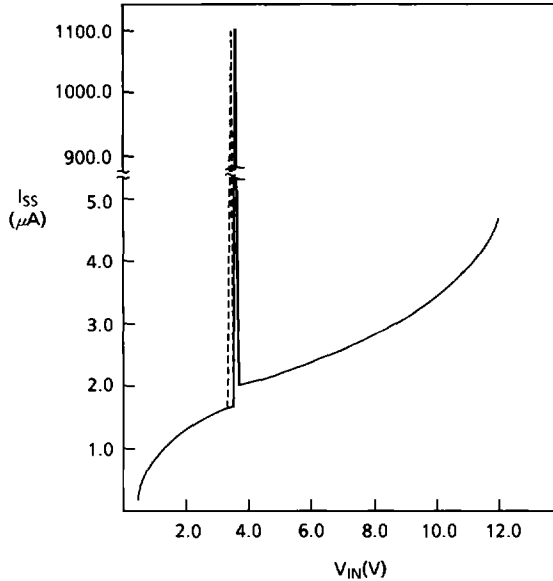

Broken line:

Current consumption characteristics when power supply voltage is less than 12 V. Where through type voltage flows is a detection voltage.

Continuous line:

Current consumption characteristics when power supply voltage rises. Where through type voltage flows is a release voltage.

5. Dynamic response

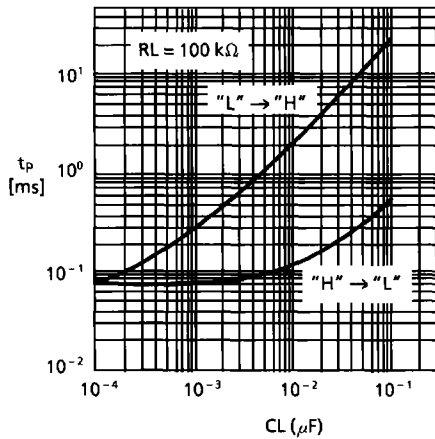

6. Minimum operating voltage

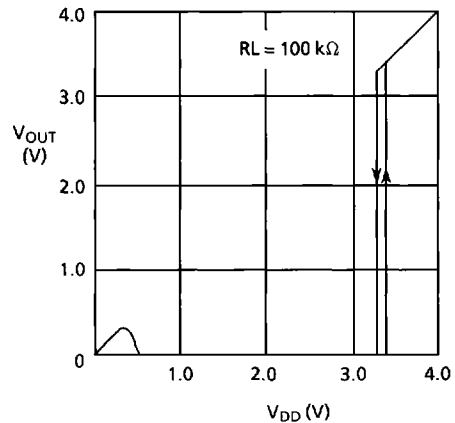

\*  $t_p$  (L→H) is decided by load resistance and load capacitance.

# VOLTAGE DETECTOR

## S-805 Series

### 7. Measuring circuits

(1) Detection voltage

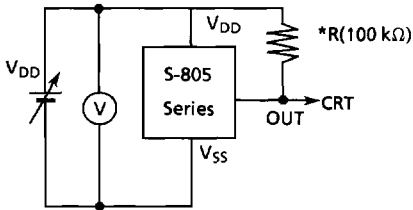

(2) Nch transistor current

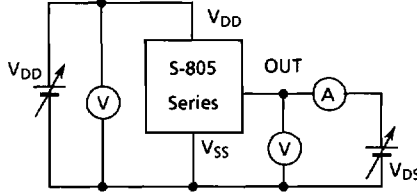

(3) Pch transistor current

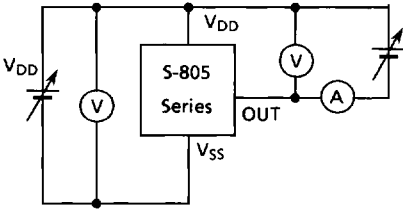

(4) Current consumption

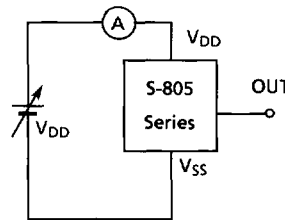

(5) Dynamic response characteristics

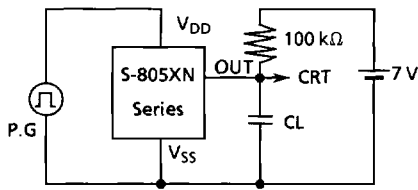

(6) Minimum operating voltage

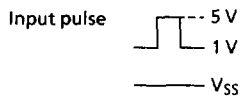
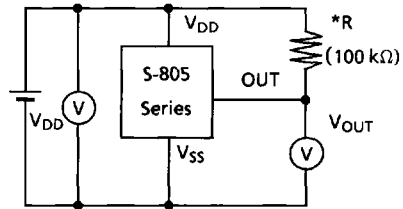

\*R is unnecessary for CMOS output products.

Figure 19 Measuring circuits

■ Application Circuit Examples

1. Reset circuits of microcomputers

If the power supply voltage to a microcomputer falls below the specified level, unspecified operation may be performed or the contents of the memory register may be lost. When power supply voltage returns to normal, the microcomputer may need to be initialized before normal operations can be done.

Reset circuits protect microcomputers, in the event of current being momentarily switched off or lowered.

With the S-805 Series, the reset circuits shown in Figures 20 to 22 can be easily constructed.

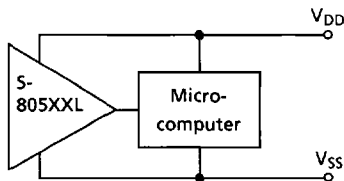
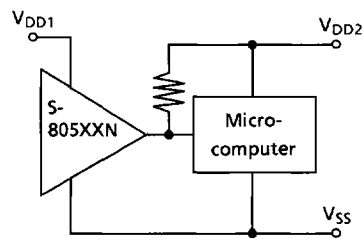

Figure 20



(Nch opendrain output products only)

Figure 21

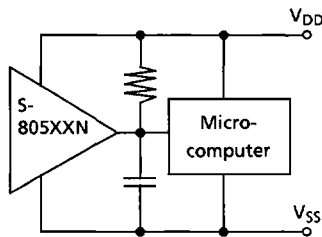

Figure 22

2. Power-on reset circuit

The Nch opendrain output products of the S-805 Series can construct a power-on reset circuit. Following is an example.

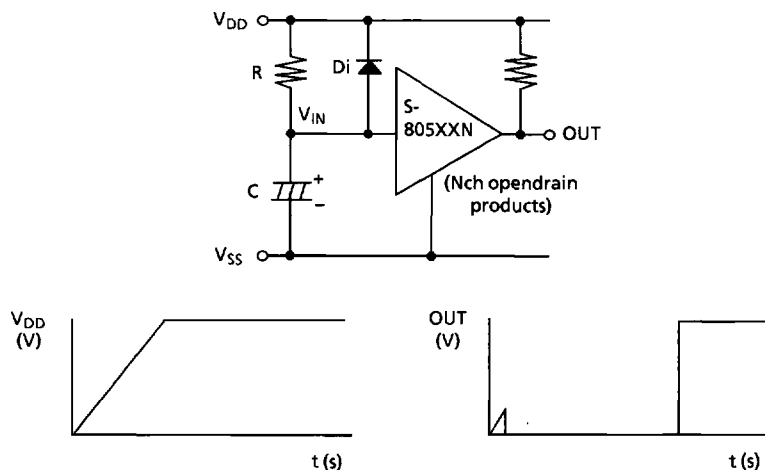

Figure 23

# VOLTAGE DETECTOR

## S-805 Series

### 3. 5-V power line monitoring circuit

When driving IC with 5-V power line, the minimum operating voltage is generally guaranteed at 4.5 V. Using the S-8054HNM, the monitoring circuit, which resets between 4.5 V and 4.7 V and releases between 4.6 V and 4.8 V, is easily composed.

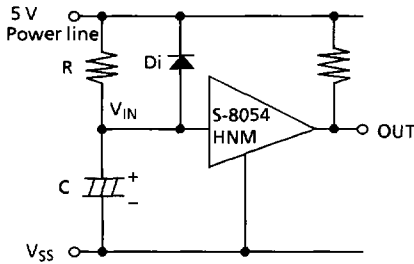

Figure 24

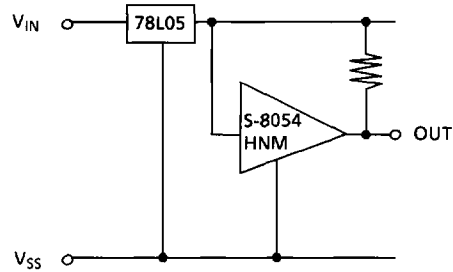
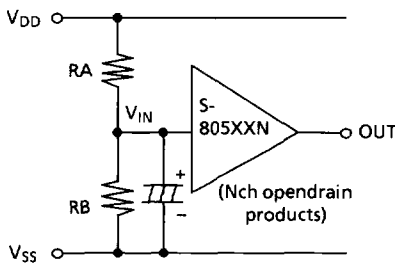

Figure 25

### 4. Change of detection voltage

In Nch opendrain output products of the S-805 Series, detection voltage can be changed with resistance dividers or diodes as shown in Figures 26 and 27. In Figure 26, hysteresis width is also changed.



$$\text{Detection voltage} = \frac{RA + RB}{RB} \cdot -V_{DET}$$

$$\text{Hysteresis width} = \frac{RA + RB}{RB} \cdot -V_{HYS}$$

The hysteresis width will be a little wider than the value of the formula above by through current if RA and RB is larger.

Figure 26

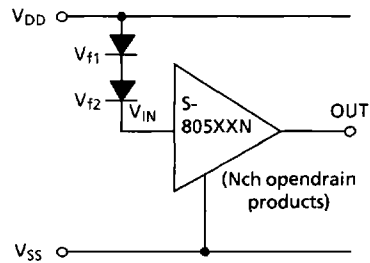

$$\text{Detection voltage} = V_{f1} + V_{f2} + -V_{DET}$$

Figure 27

### 5. Malfunction analysis

Figure 28 shows a circuit example for analysing malfunctions by monitoring power supply voltage or whimsical noise.

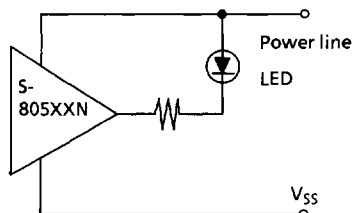

Figure 28



6. Battery backup of memories

Figure 29 shows a circuit example of battery backup for maintaining the memory contents if power is turned off or falls suddenly. During battery backup (when main power is off or main voltage is low), power is supplied from battery to RAM and control decoder by diode  $Di_2$ , and the S-805 Series makes the enable input of chip select decoder to "0". At that time, all outputs of the chip select decoder become "1" so that all RAMs are in the non-access state.

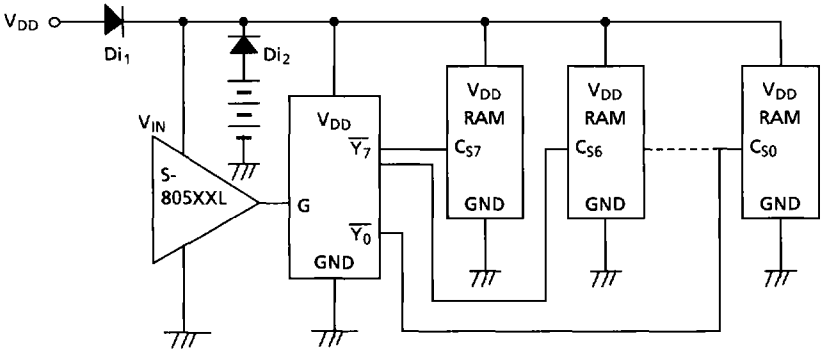

Figure 29

7. Charge monitoring circuit

Figure 30 shows a charge monitoring circuit for protection against battery deterioration by an overcharge. When the power supply voltage is higher than the set detection voltage,  $Tr$  turns ON and dump current is bypassed to  $Tr$ . Therefore the battery cannot be overcharged.

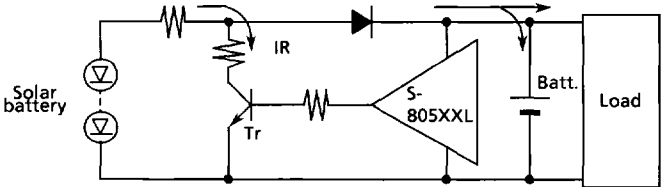

Figure 30

8. Level selector

Figure 31 shows a logic level selector.

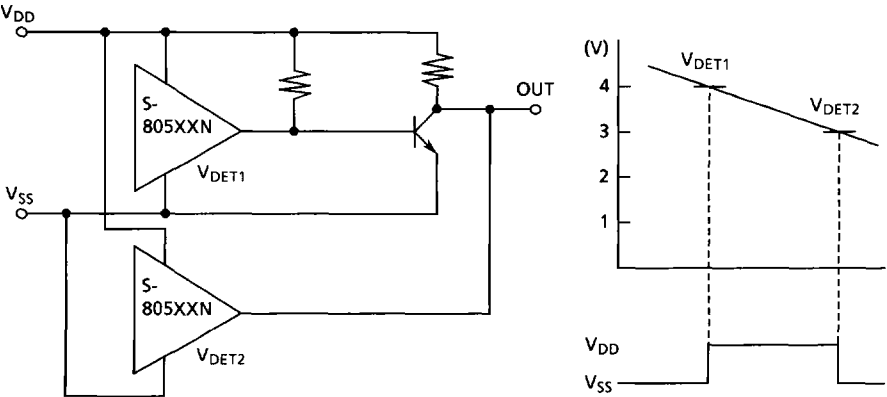

Figure 31

## VOLTAGE DETECTOR

### S-805 Series

---

#### ■ Notes

- In CMOS output products of the S-805 Series, high through current flows when detecting or releasing. If high impedance is connected to input, oscillation may be caused by the through current when lowering the voltage during releasing.
- In TO-92 products, since there are projection and resin burr on roots of lead terminals formed at Tiebar-cut, do not solder on them.
- When designing for mass production using an application circuit described here, keep the deviation of components and temperature characteristic.
- Seiko Instruments Inc. cannot take any responsibility for the patents on the circuits described here.