

# CMI-MMPP10055LH-SERIES

## Features

- ▶ High current and low profile
- ▶ Metal powder molding type for EMC protection.
- ▶ Available tape and reel for auto insertion.
- ▶ Halogen-Free / RoHS compliant.

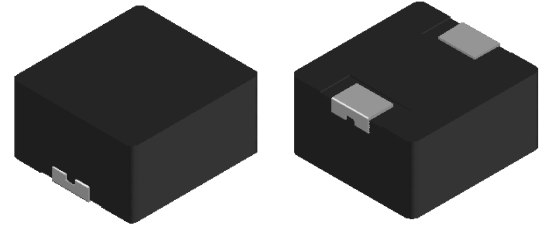

## Applications

- ▶ For DC/DC converter, AV equipment digital consumer electronics

**Dimension (Unit:mm)**

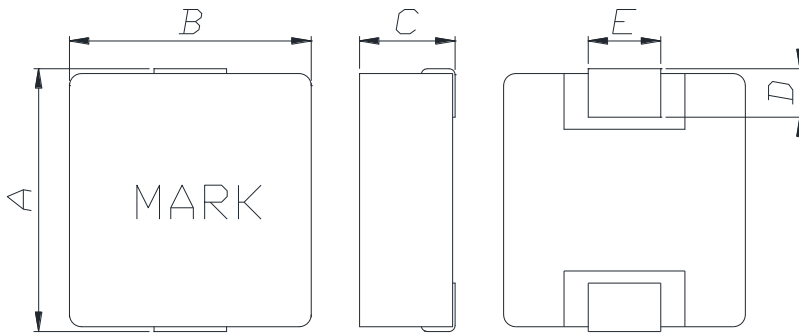

A	B	C	D	E
10.85±0.5	10.0±0.4	5.5 Max	2.0±0.3	3.0±0.2

**Land Pattern (Unit:mm)**

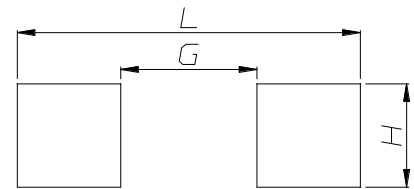

L	G	H
13.6	5.4	4.1

## Regulation of part number

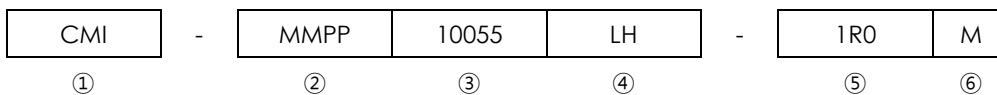

- ① CoilMaster's initial
- ② Series Name : Metal Molded Pin type Power inductor
- ③ Core Size (unit:mm)
- ④ Material
- ⑤ Typical inductance value (1.0uH)
- ⑥ Inductance tolerance (±20%)

• **You can also contact us by e-mail : [coilmaster@coilmaster.com](mailto:coilmaster@coilmaster.com)**  
 • All specifications are subject to change without notice.  
 • Update date : 2023.03.31



# Electrical characteristics

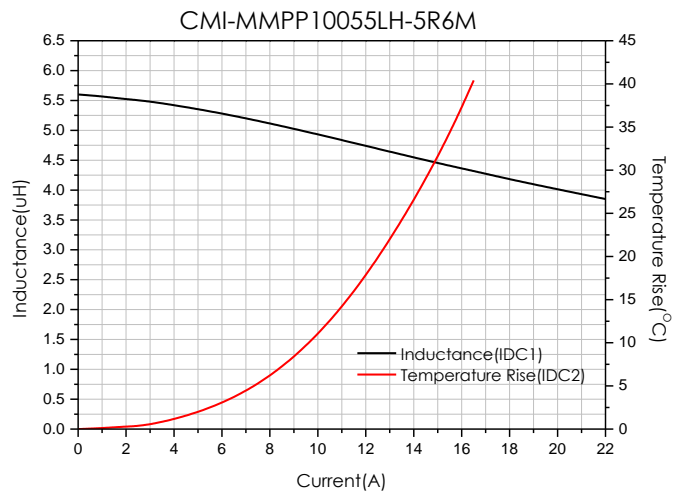
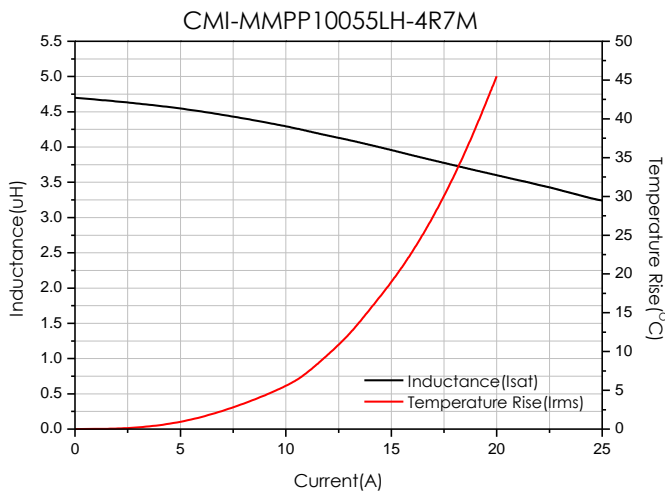
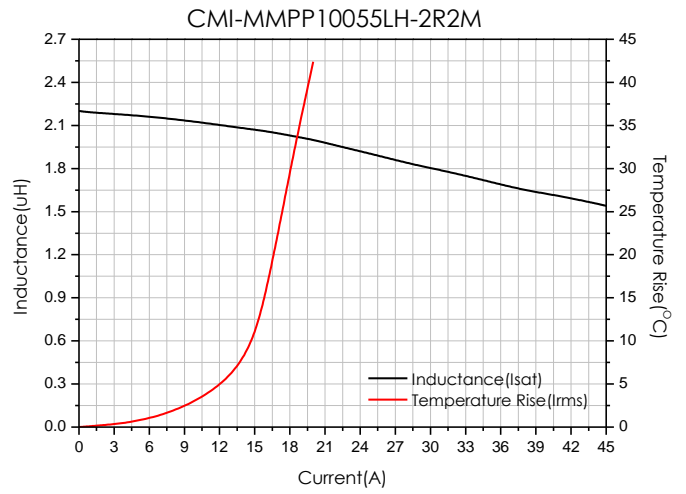
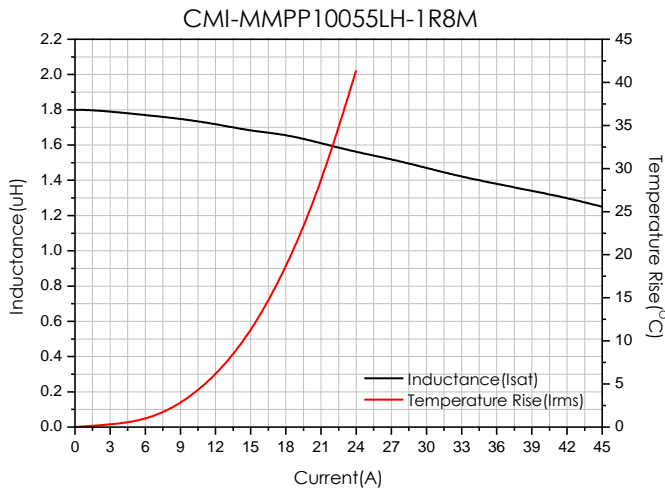
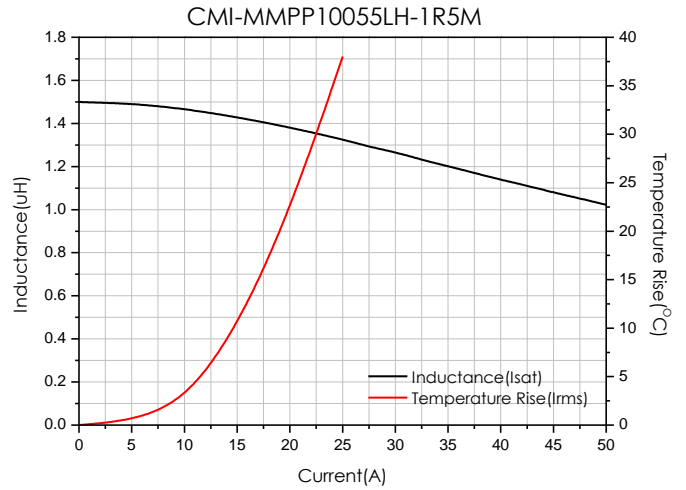
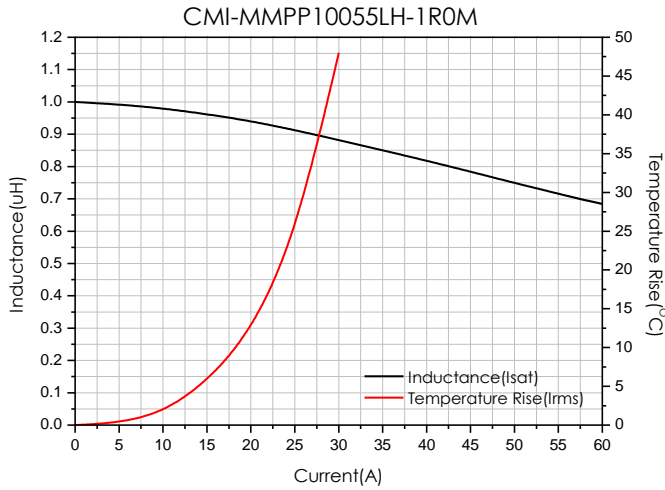

- You can also contact us by e-mail : [coilmaster@coilmaster.com](mailto:coilmaster@coilmaster.com)
- All specifications are subject to change without notice.
- Update date : 2023.03.31

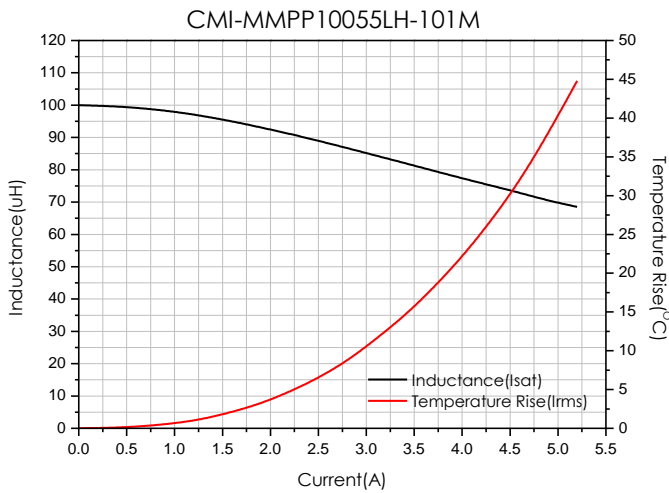
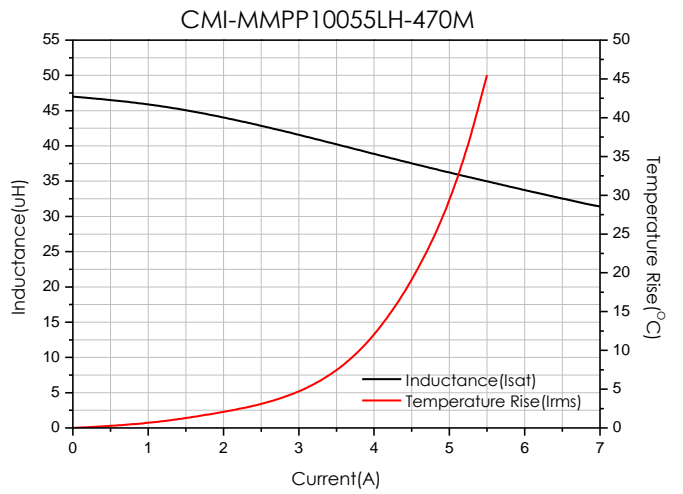
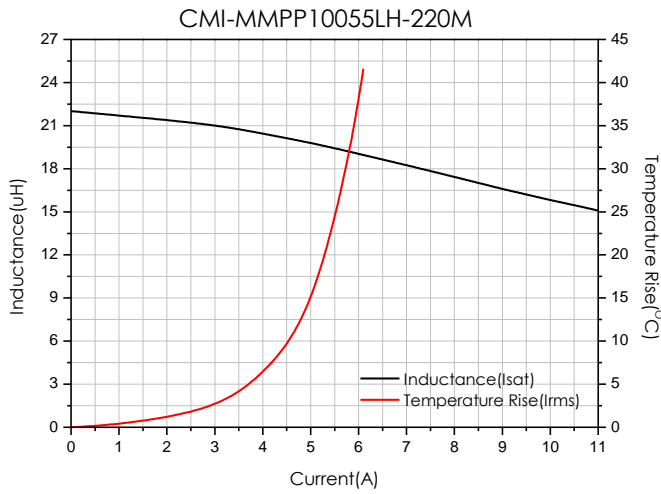
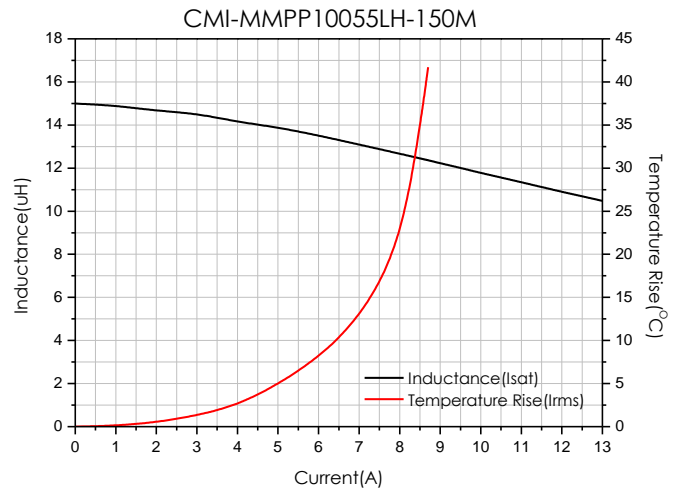
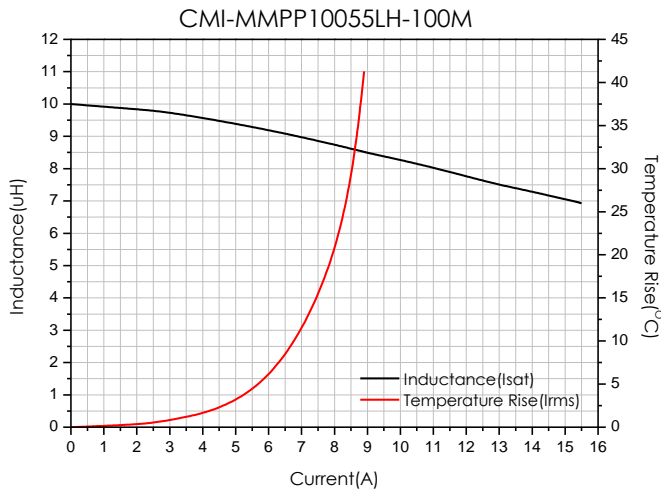

- You can also contact us by e-mail : [coilmaster@coilmaster.com](mailto:coilmaster@coilmaster.com)
- All specifications are subject to change without notice.
- Update date : 2023.03.31

## Packaging

(1) Package quantity : 600 (pcs/reel)

(2) Reel Dimensions (unit:mm)

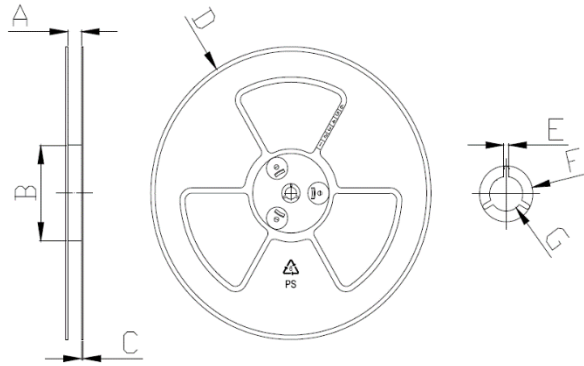

A	B	C	D	E	F	G
24.50	100.0	2.30	330.0	2.30	21.50	13.00
+0.50	+1.00	+0.20	+3.00	+0.30	+0.30	+0.50
-0.50	-1.00	-0.20	-3.00	-0.30	-0.30	-0.20

(3) Tape Dimensions

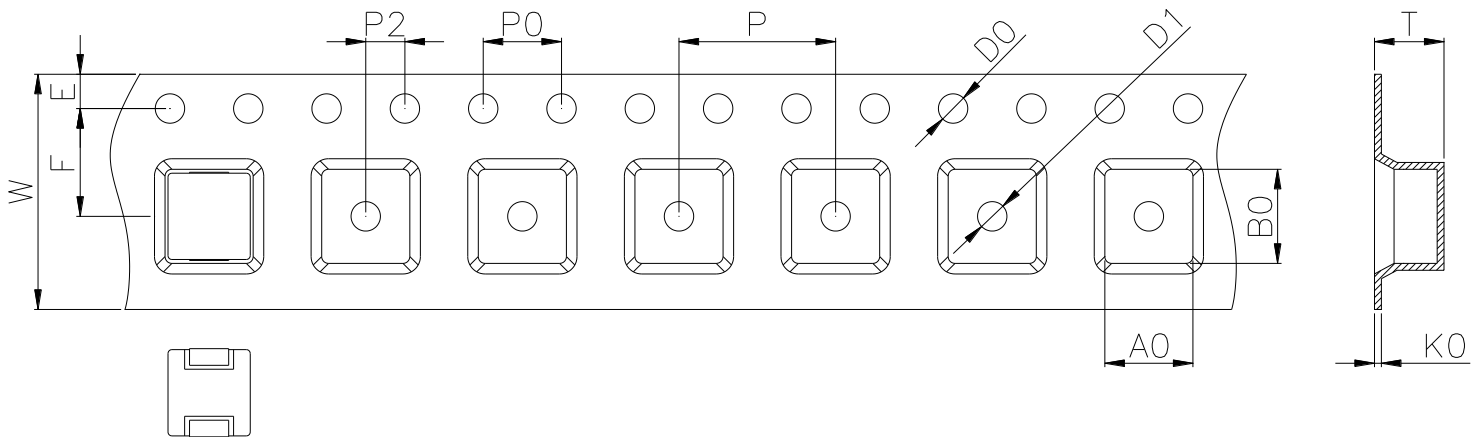

W	A0	B0	K0	E	F	P	P0	P2	D0/D1	T
24.00	10.60	11.45	5.70	1.75	11.50	16.00	4.00	2.00	1.50	0.40
+0.30	+0.10	+0.10	+0.15	+0.10	+0.10	+0.10	+0.10	+0.10	+0.10	+0.05
-0.10	-0.10	-0.10	-0.10	-0.10	-0.10	-0.10	-0.10	-0.10	-0.00	-0.05

Ilisan Sales Office (KOREA) +82)31-904-1444  
 China Sales Office (CHINA) +86)758-278-7031  
 Hungary Sales office (EUROPE) +36)1-899-8543

H.K Sales Office (HONGKONG) +852)2711-5551  
 LA Sales Office (USA) +1)866-446-3586

• You can also contact us by e-mail : [coilmaster@coilmaster.com](mailto:coilmaster@coilmaster.com)

- All specifications are subject to change without notice.
- Update date : 2023.03.31

[www.coilmaster.com](http://www.coilmaster.com)