

# CMI-MMP252012BS-SERIES

## Features

- ▶ Small size, Low profile, Compact design
- ▶ Metal powder molding type for EMC protection.
- ▶ Available tape and reel for auto insertion.
- ▶ Halogen-Free / RoHS compliant.

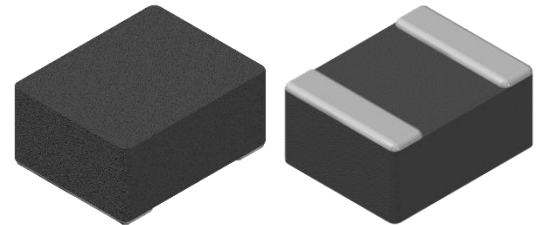

## Applications

- ▶ For DC/DC converter  
(PMIC, Mobile phone, Tablet, TV, Audio, Display, HDD, SSD etc.)

### Dimension (Unit:mm)

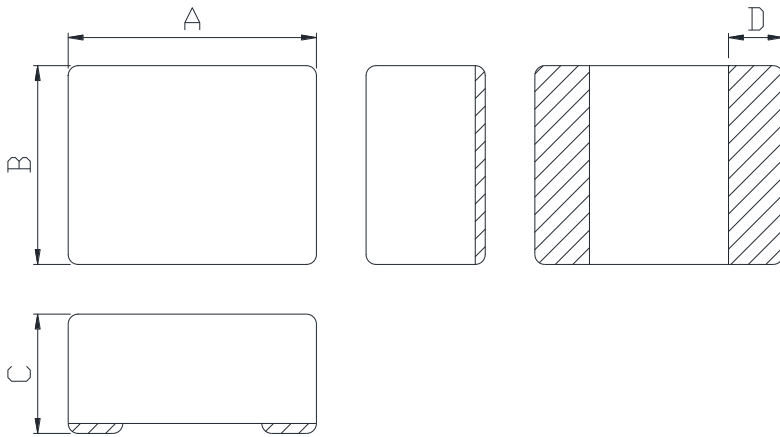

A	B	C	D
2.5±0.2	2.0±0.2	1.2 Max.	0.55±0.25

### Land Pattern (Unit:mm)

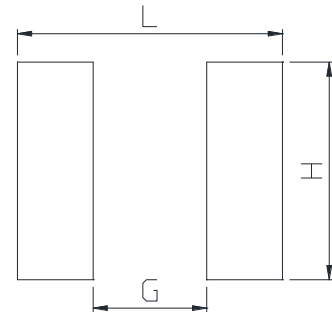

L	G	H
2.8	1.2	2.3

## Regulation of part number

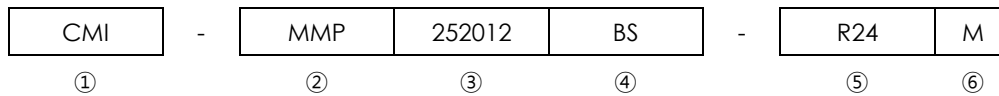

- ① CoilMaster's initial
- ② Series Name : Metal Molded Power inductor
- ③ Core Size (unit:mm)
- ④ Type
- ⑤ Typical inductance value (0.24uH)
- ⑥ Inductance tolerance (±20%)

## Specifications

Part Number	Inductance (uH) ±20%	DCR(mohm) Max.(Typ.)	Isat(A) Max.(Typ.)	Itemp(A) Max.(Typ.)	Test Frequency (Hz)
CMI-MMP252012BS-R24M	0.24	21.6(18)	7.8(8.2)	6.0(6.3)	1M
CMI-MMP252012BS-R33M	0.33	25.2(21)	6.6(7.0)	5.0(5.3)	1M
CMI-MMP252012BS-R47M	0.47	36(30)	6.2(6.7)	4.0(4.4)	1M
CMI-MMP252012BS-R68M	0.68	45.6(38)	5.4(5.9)	3.6(4.0)	1M
CMI-MMP252012BS-1R0M	1.0	66(47)	4.0(4.4)	3.0(3.3)	1M
CMI-MMP252012BS-1R2M	1.2	72(60)	3.6(3.9)	2.7(3.0)	1M
CMI-MMP252012BS-1R5M	1.5	80(67)	3.1(3.4)	2.4(2.7)	1M
CMI-MMP252012BS-2R2M	2.2	114(95)	2.6(2.9)	2.0(2.2)	1M
CMI-MMP252012BS-3R3M	3.3	168(140)	2.3(2.6)	1.8(2.0)	1M
CMI-MMP252012BS-4R7M	4.7	240(200)	1.7(1.9)	1.3(1.5)	1M
CMI-MMP252012BS-6R8M	6.8	300(250)	1.4(1.6)	1.1(1.3)	1M
CMI-MMP252012BS-100M	10	456(380)	1.1(1.3)	0.9(1.1)	1M

- Isat: When based on the inductance change rate (approximately 30% below in the initial value)
- Itemp: When based on the temperature increase (Temperature increase of approximately 40°C by self heating)
- Operating Temperature Range(including self temperature) : -40°C ~ +125 °C

Note 1 : Circuit design, component placement, PCB trace size and thickness, airflow and other cooling. Provision all affect the part Temperature. Part temperature should be verified in the end application.

▪ **You can also contact us by e-mail : [coilmaster@coilmaster.com](mailto:coilmaster@coilmaster.com)**

- All specifications are subject to change without notice.
- Update date : 2023.05.16

[www.coilmaster.com](http://www.coilmaster.com)

## Packaging

(1) Package quantity : 3,000 (pcs/reel)

(2) Reel Dimensions (unit:mm)

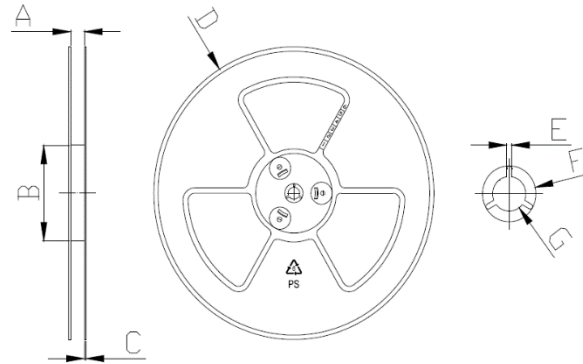

A	B	C	D	E	F	G
8.50	60.0	1.50	178.0	2.70	22.50	13.50
+0.50	+2.00	+0.20	+1.00	+0.30	+0.50	+0.50
-0.50	-2.00	-0.20	-1.00	-0.30	-0.50	-0.50

(3) Tape Dimensions

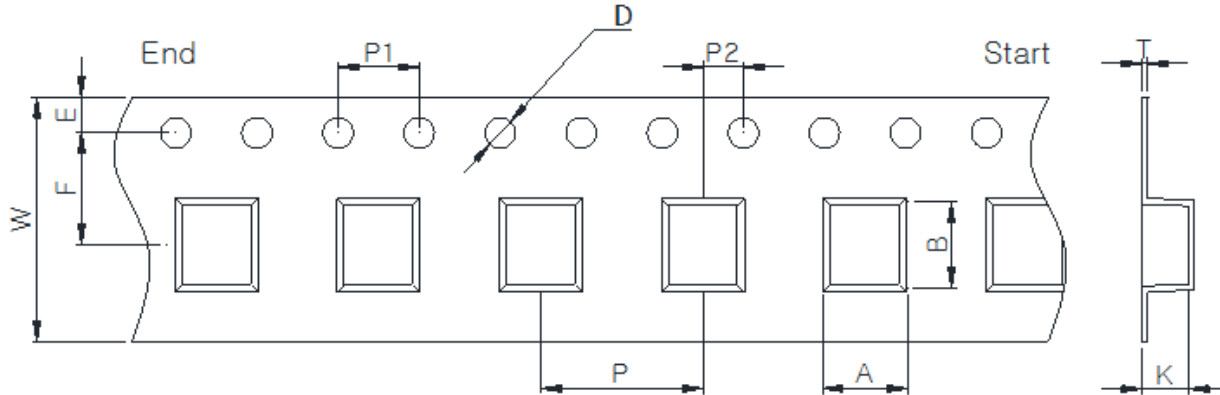

W	A	B	K	E	F	P	P1	P2	D	T
8.00	2.45	3.05	1.30	1.75	3.50	4.00	4.00	2.00	1.50	0.30
+0.10	+0.10	+0.10	+0.10	+0.15	+0.10	+0.10	+0.10	+0.05	+0.10	+0.05
-0.10	-0.10	-0.10	-0.10	-0.10	-0.10	-0.10	-0.10	-0.05	-0.00	-0.05

Korea Sales Office (KOREA) +82)31-904-1444  
 China Sales Office (CHINA) +86)0758-683-1444  
 Hungary Sales office (EUROPE) +36)1-404-5832

H.K Sales Office (HONGKONG) +852)2711-5551  
 LA Sales Office (USA) +1)714-616-6989

• You can also contact us by e-mail : [coilmaster@coilmaster.com](mailto:coilmaster@coilmaster.com)

- All specifications are subject to change without notice.
- Update date : 2023.05.16

[www.coilmaster.com](http://www.coilmaster.com)